

# *Model R-DF* High-Velocity Fans

---



MoffittCorp.com | (800) 474-3267  
1351 13th Ave S. Suite 130  
Jacksonville Beach, FL 32250

 **Moffitt**  
NATURAL VENTILATION SOLUTIONS

# Model R-DF High-Velocity Dock Fans

---

## Model R-DF Dock Fans Description

### PRODUCT DESCRIPTION

Model R-DF Dock Fans recirculate air throughout the loading docks. Developed by Romlair Fan Company, this fan is also known as the “Romulator”. The powerful blowers greatly increase air velocity, pushing air deep inside of a 53’ trailer. This solution improves comfort and productivity during loading and unloading.

R-DF Fans generate air speeds 3 or 4 times higher than a conventional fan.

Romlair offers up to 3 Dock Fans designed to circulate air at high speed inside from the dry box. The inside of dry boxes often becomes extremely hot while they are parked in the platform area. Loading and unloading trucks at high temperatures can impair performance and even be dangerous. These High-speed fans are installed on the platform curtain to inject fresh air along the platform.

### STANDARD FEATURES

- Motor Drive: Direct
- Nozzle: Attractive nozzle design with spun inlet bell
- Air Straightener: Integral to reduce air swirl
- Propeller: High-performance blade
- Guards: Heavy-duty safety guards on both the inlet and outlet ends
- Power Cord: Furnished for all 115v units
- Coating: Fan housing coated with thermally fused powdered polyurethane black finish.
- Power: Low amp applications

### OPTIONAL FEATURES

- Weather Hoods
  - 45° (Relief)
  - 90° (Intake)

### MODELS

- R-DF-14 - Dock fan recommended for trucks up to 26 ft long
- R-DF-18 - Dock Fan recommended for semi-trailer trucks up to 53 ft long

### INDUSTRY APPLICATION

### BENEFITS

- Forces the release of smoke and odors generated by the forklift while maneuvering inside the box dry.
- The platform fans have a minimum obstruction in the curtain, so the forklift can maneuver easily.
- Helps reduce heat inside the dry box avoiding damage to the health of personnel.
- High speed air flow creates a cooling effect freshness increasing staff productivity while loading and unloading the merchandise.

# Model R-DF High-Velocity Dock Fans

## Model R-DF-14 Specifications

### STANDARD FEATURES

- Propeller: 14" Diameter Propeller
- Housing: Galvanized Sheet Housing
- Paint: Traffic yellow finish standard, custom colors available.
- Guards: Guards according to OSHA
- Power Cord: 12 FT of Cable with Plug (115V Only)
- Warranty: 1 year warranty
- 1/4 HP Direct Drive Motor, 1725 RPM
- Voltage Options:
  - 1 Phase 115/230V, 5.4/2.7 AMPS
  - 1 Phase 277V, 2.1 AMPS
  - 3 Phase 230/460V, 1.4/0.7 AMPS

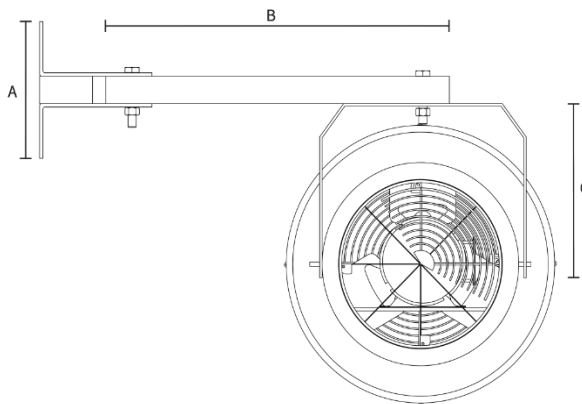

Front View

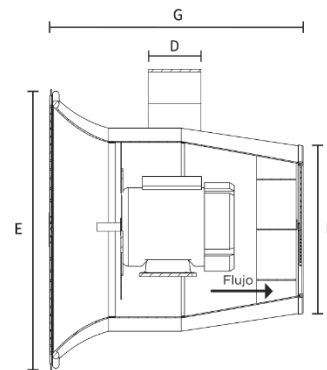

Side View

Model	CFM	Distance	A	B	C	D	E	F	G	Weight
R-DF-14	2500	55 FT	10"	26"	13"	4"	20"	12"	18.5"	71 lbs.

# Model R-DF High-Velocity Dock Fans

## Model R-DF-18 Specifications

### STANDARD FEATURES

- Propeller: 18" Diameter Propeller
- Housing: Galvanized Sheet Housing
- Paint: Traffic yellow finish standard, custom colors available.
- Guards: Guards according to OSHA
- Power Cord: 12 FT of Cable with Plug (115V Only)
- Warranty: 1 year warranty
- 1/4 HP Direct Drive Motor, 1725 RPM
- Voltage Options:
  - 1 Phase 115/230V, 5.4/2.7 AMPS
  - 1 Phase 277V, 2.1 AMPS
  - 3 Phase 230/460V, 1.4/0.7 AMPS

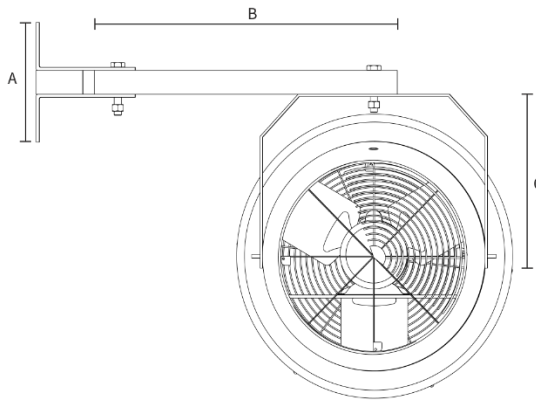

Front View

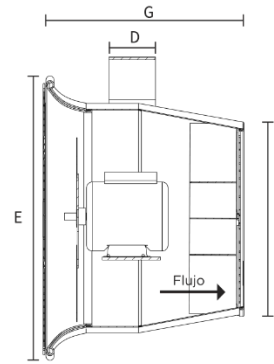

Side View

Model	CFM	Distance	A	B	C	D	E	F	G	Weight
R-DF-18	3700	75 FT	10"	26"	14"	4"	24"	16"	17"	86 lbs.

# Model R-DF High-Velocity Dock Fans

## Model RTC Fan Details

### STANDARD FEATURES

- Propeller: 14" Diameter Propeller
- Housing: Galvanized Sheet Housing
- Paint: Traffic yellow finish standard, custom colors available.
- Guards: Guards according to OSHA
- Power Cord: 12 FT of Cable with Plug (115V Only)
- Warranty: 1 year warranty
- 1/4 HP Direct Drive Motor, 1725 RPM
- Voltage Options:
  - 1 Phase 115/230V, 5.4/2.7 AMPS
  - 1 Phase 277V, 2.1 AMPS
  - 3 Phase 230/460V, 1.4/0.7 AMPS

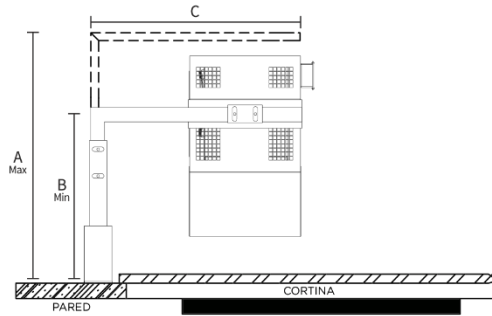

Front View

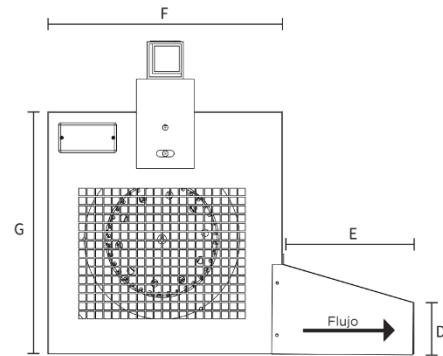

Side View

Model	CFM	Distance	A	B	C	D	E	F	G	Weight
RTC	3100	55 FT	30"	22"	30.5"	35"	5"	16"	16"	137 lbs.

# Model R-DF High-Velocity Dock Fans

---

## Model R-DF Fan Comparison

Conventional fans produce low speed airflow with fast dissipation, and they tend to trap hot air inside the dry box. Additionally, commercial fans can get in the way and be easily damaged.

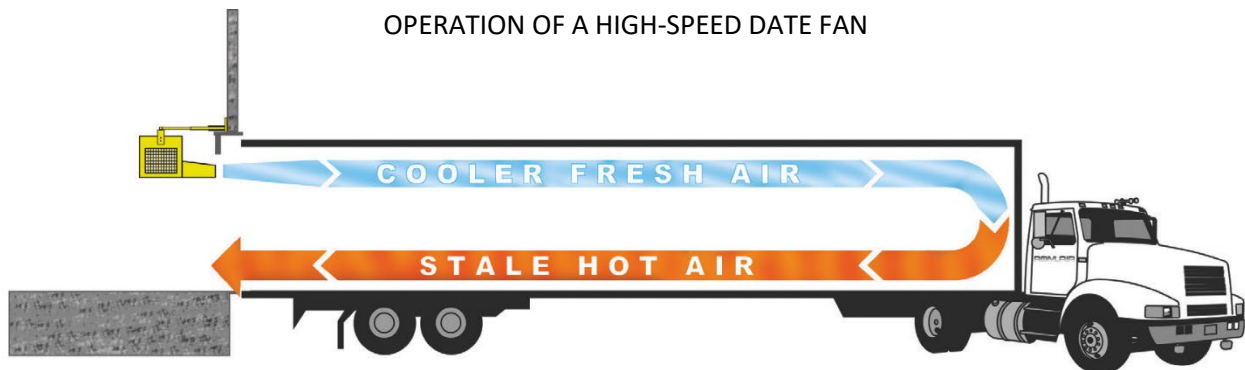
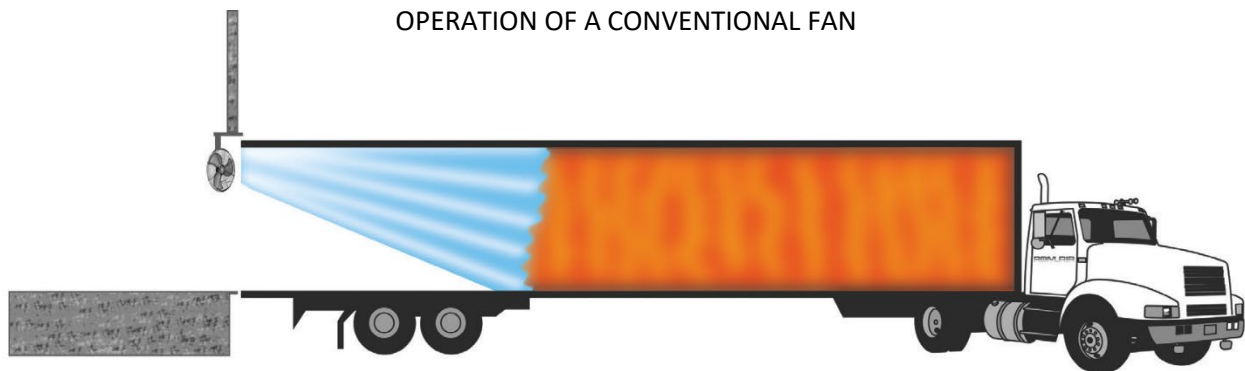

*The upper part of the trailer box stays cool and dry, forcing the hot air to exit at the floor level. This cycle reduces the heat of the enclosed area.*